

□□□□

□□“□□□□”□□□□□□“□□□□”□□□□“□□□□”□□□□“□□□□”□□□□“□□□□”□□□□□□□□

□□□□

□□□□	SF-30A □□ □□ 9.0*56.0
□□□□	≥9.0mm
□□□□	2500g±15%gf@ □□ 5.0mm 600g±15%gf@ □□ 2.0mm
□□□□	200PCS
□□	□□□□□□
□□□□	100% T/T □□□
□□□□	5-10 □ □□ □□□

□□ □□

# SFENG

The China's The World's



[WWW.SF-PROBE.COM](http://WWW.SF-PROBE.COM)

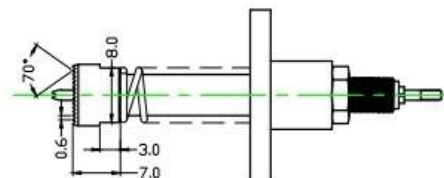
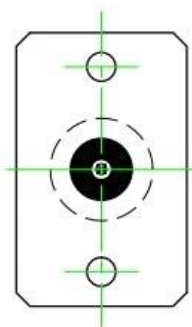
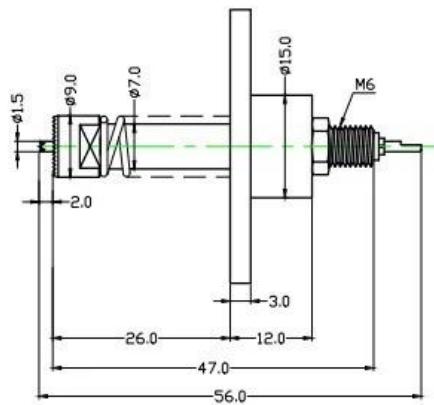
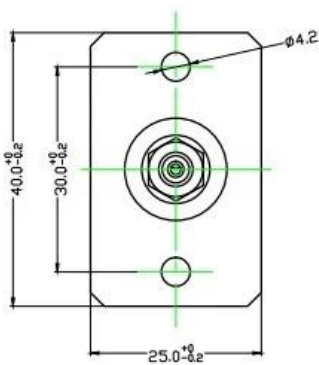



## Production Flow (生产流程)

**SFENG**  
The China's The World's



**1. raw material warehouse**



**2. Lathe workshop**



**3. Assemble workshop**



**4. Quality inspection**



**5. Finished products**



**6. Packing**



## Measuring Equipment >

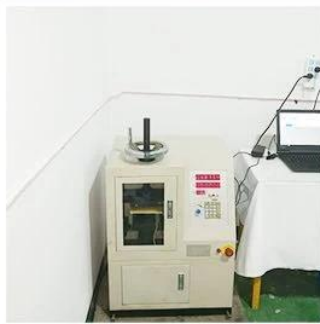
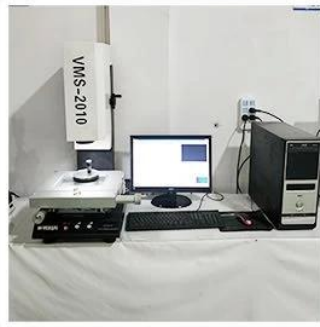
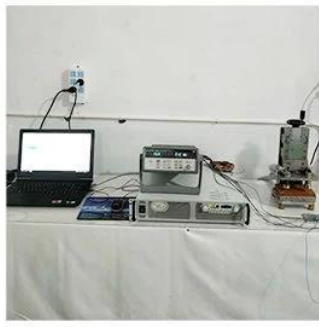

### Measuring Equipment:

1. Agilent current testing;
2. Quadratic element measurement
3. Load Curve Meter
4. Bond Test
5. Life Fatigue Test





□□ □□



# QMS CERTIFICATE OF REGISTRATION

Registration No.: 12815Q20988R0S

This is to certify that the Quality Management System of  
**Suzhou Shengteng Electronic Co., Ltd.**

Organization code :55025791-9

Registered address: Suzhou high tech Zone Binhe Road, No.588 SEG electronics market 3D01 room  
215400 P.R.China

Has been audited to conform to the following Quality Management  
System Standard:  
GB/T19001-2008

For the whole process of  
Sales of probe and related accessory

First S.A.	贴标处
------------	-----

Second S.A.	贴标处
-------------	-----

Third S.A.	贴标处
------------	-----

The term of validity of the certificate, the certificate shall be at least once a year surveillance audit, With qualified logo, for the effective certificate. The certificate information is available in the certification and Accreditation Administration of the People's Republic of China's official website: [www.cnca.gov.cn](http://www.cnca.gov.cn)

DATE OF ISSUE: 09-11-2015

DATE OF SUPERVISION : 09-11-2015

VALID UNTIL: 09-10-2018



Management System  
CNAS C128-Q

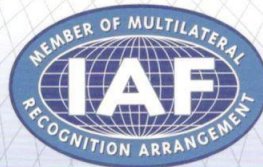

Room 703, Building 1, No. 22, B, Fuchengmenwai Street,  
Xicheng District, Beijing  
010-68396010



1. PCB ICT FCT
2. Pogo pin
3. BGA
4. LM QZ VZ
- 5.
6. &
7. POM

□□□ □□

1. 24
2. OEM
- 3.
- 4.