

Materials (Plated) (材質與鍍層):
 Barrel (針套) : Brass (黃銅) , Ni Plated
 Plunger (針軸) : SUS (不銹鋼) , /
 Spring (彈弓) : SUS (不銹鋼) , /

Specifications (技術要求):
 Full Stroke (滿沖程) : 3.5mm
 Rated Stroke (額定沖程) : 3.0mm
 Spring Force (額定彈力) : 10-30gf @ load 3.0mm

					名称:		胜峰科技	
					SF-Pogo pin 4.0X13.0-J1.6		说明:	
标记处数					更改文件号		1. 所有尺寸单位为mm	
设计					标准化		2. 未注图示尺寸公差:按GB1804-79 11级精度执行	
校对					审定		图纸编号: SFKJ-20190408-044 (1)	
审核					制图 HJQ			
工艺					日期 2019-4-8		共 1 页 第 1 页	

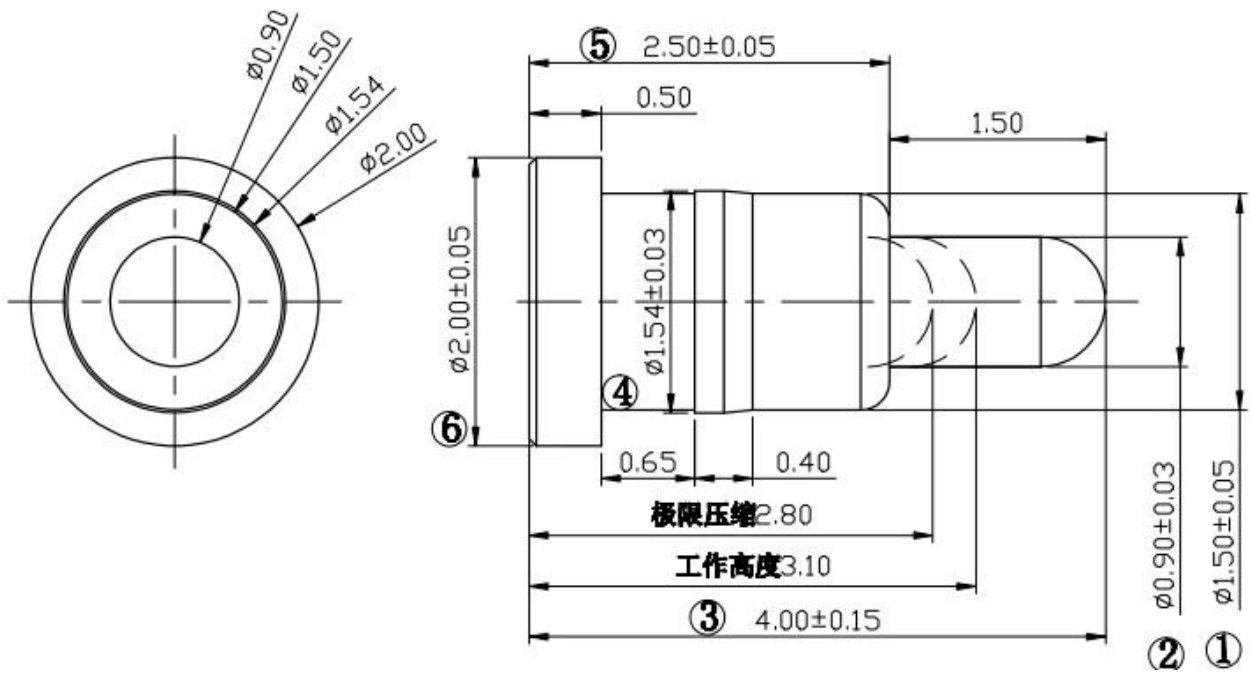

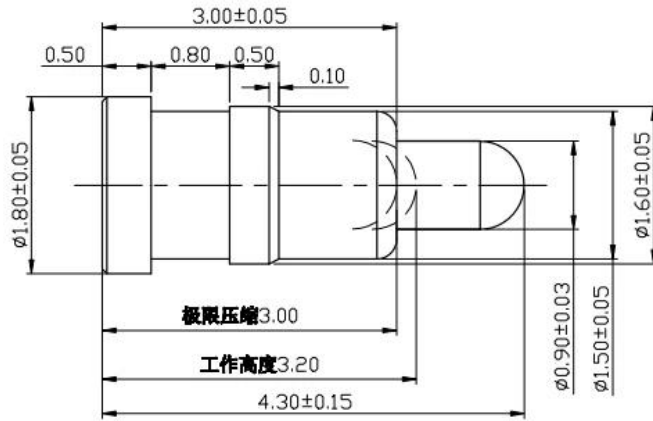

NOTE

- 1. Material
Plunger: Brass 3604
Barrel: Brass 3604
Spring: SUS304
Housing:
- 2. Plating
Plunger: Au 10u" over 50~120u" Ni
Barrel: Au 10u" over 50~120u" Ni
Spring:
- 3. Electrical
Rated current & voltage: DC 12V; 1.0A Max.



1. 24
2. OEM
- 3.
- 4.



1. PCB ICT FCT
2. Pogo pin
3. BGA
4. QZ VZ LM
- 5.
6. /
7. 30# OK POM





1. Raw material warehouse



2. Lathe workshop



3. Assemble workshop



4. Quality inspection



5. Finished products



6. Packing



1. Agilent current testing



2. Quadratic element



3. Load Curve Meter



4. Bond Test



5. Life Fatigue Test



6. Microscope



A5: [Placeholder]

Q6. [Placeholder]

A6: [Placeholder]

Q7. [Placeholder] **OEM** [Placeholder] **ODM** [Placeholder]

A7: [Placeholder] OEM/ODM [Placeholder]

Q8. [Placeholder]

A8: [Placeholder]