

□□□□□□

SFENG 1984 探针系列 () 探针系列

□□□□□

SF-PH15-B3

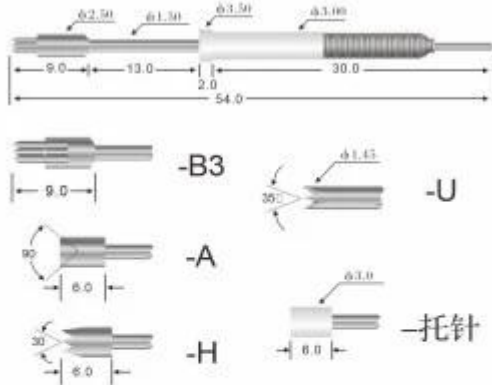

SF-PH18-B3

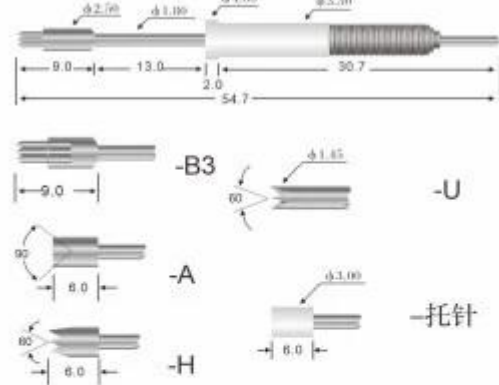

SF-PH101-B3

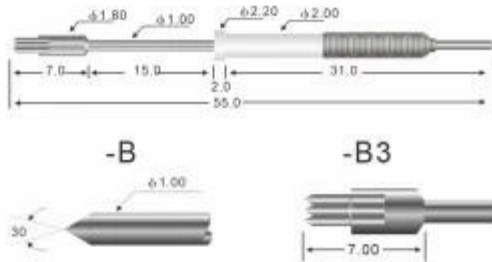

SF-PM200-B3

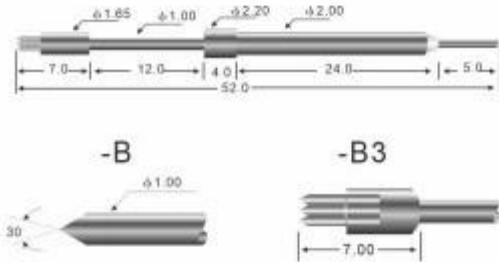

技术规格
PROBE SPECIFICATIONS

	SF-PH15	SF-PH18	SF-PH101	SF-PM200
Recommended minimum center 最小间距	3.50mm(.1378 ")	4.30mm(.1693 ")	2.54mm(.1000 ")	2.54mm(.1000 ")
Mounting hole size 钻孔尺寸	3.00mm(.1181 ")	3.50mm(.1378 ")	2.00mm(.0787 ")	2.00mm(.0787 ")
Full travel 行程	13.0(.5118 ")	13.0(.5118 ")	15.0(.5905 ")	12.0(.4724 ")
Spring force 弹簧压力	300g	300g	300g	300g
Current rating 额定电流	5A(安培)	5A(安培)	5A(安培)	5A(安培)
Contact resistance 接触电阻	50m Ω (毫欧姆)	50m Ω (毫欧姆)	50m Ω (毫欧姆)	50m Ω (毫欧姆)

□□□□□□:

品名	SF-PH18
規格	4×3mm×.1693"
厚度	3.50mm×.1378"
長度	13.0×.5118"
重量	300個
電流	5A
電阻	50mΩ
MOQ	100
備註	標準規格7個

品質保證

1. 品質保證24個月
2. 品質保證期間內免費維修
3. 品質保證期間內免費換貨
4. 品質保證期間內免費退貨

技術規格

1. PCB ICT FCT 檢驗合格
2. 品質保證期間內免費維修 2 個月
3. BGA 檢驗合格
4. 品質保證期間內免費換貨 QZ VZ LM
5. 品質保證期間內免費退貨
6. 品質保證期間內免費換貨
7. 品質保證期間內30# OK POM

品質保證期間內免費換貨

品質保證





1. Raw material warehouse



2. Lathe workshop



3. Assemble workshop



4. Quality inspection



5. Finished products



6. Packing



1. Agilent current testing

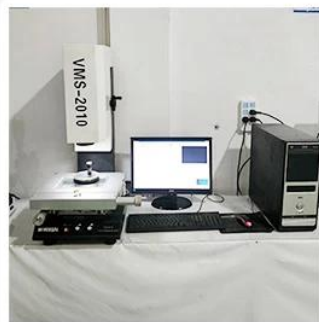

2. Quadratic element



3. Load Curve Meter



4. Bond Test



5. Life Fatigue Test



6. Microscope



Q1. 請說明貴公司

A1: 貴公司目前主要經營之產品及服務內容為何？

Q2. 請說明貴公司

A2: 貴公司目前之主要客戶群為何？QC 之主要來源為何？目前之主要市場為何？1. 請說明貴公司

Q3. 請說明貴公司

A3: 貴公司目前之主要競爭對手為何？

Q4. 請說明貴公司

A4: 貴公司目前之主要產品及服務內容為何？

Q5. 請說明貴公司

A5: 貴公司目前之主要客戶群為何？

Q6. 請說明貴公司

A6: 貴公司目前之主要競爭對手為何？

Q7. OEM 與 ODM 有何區別？

A7: 貴公司目前之主要客戶群為何？OEM / ODM 之區別為何？P 之區別為何？

Q8. 請說明貴公司

A8: T/T 與 L/C 之區別為何？MOQ 之區別為何？

請說明貴公司

請說明貴公司 DHL UPS FedEx TNT EMS 之區別為何？

請說明貴公司 Exwork FOB CNF CIF 之區別為何？



2023 ISO Certificate



Patent for Coaxial Structure



Patent for Honeycomb current probe









□□□□□□



CIBF2021

苏州胜亿福睿电子科技有限公司
Suzhou Shengyifurui Electronic Technology Co., Ltd

No.3B013

