

Materials (Plated) (材質與鍍層):  
 Barrel (針套) : Brass (黃銅) , Ni Plated  
 Plunger (針軸) : SUS (不銹鋼) , /  
 Spring (彈弓) : SUS (不銹鋼) , /

Specifications (技術要求):  
 Full Stroke (滿沖程) : 3.5mm  
 Rated Stroke (額定沖程) : 3.0mm  
 Spring Force (額定彈力) : 10-30gf @ load 3.0mm

					名称:		胜峰科技	
					SF-Pogo pin 4.0X13.0-J1.6		说明:	
							1. 所有尺寸单位为mm	
							2. 未注图示尺寸公差:按GB1804-79 11级精度执行	
设计	更改文件号	签字	日期	图样	标记	视图	质量	比例
校对		审定		S	A	⊕		/
审核		制图	HJQ	图纸编号: SFKJ-20190408-044 (1)				
工艺		日期	2019-4-8	共	1	页	第	1

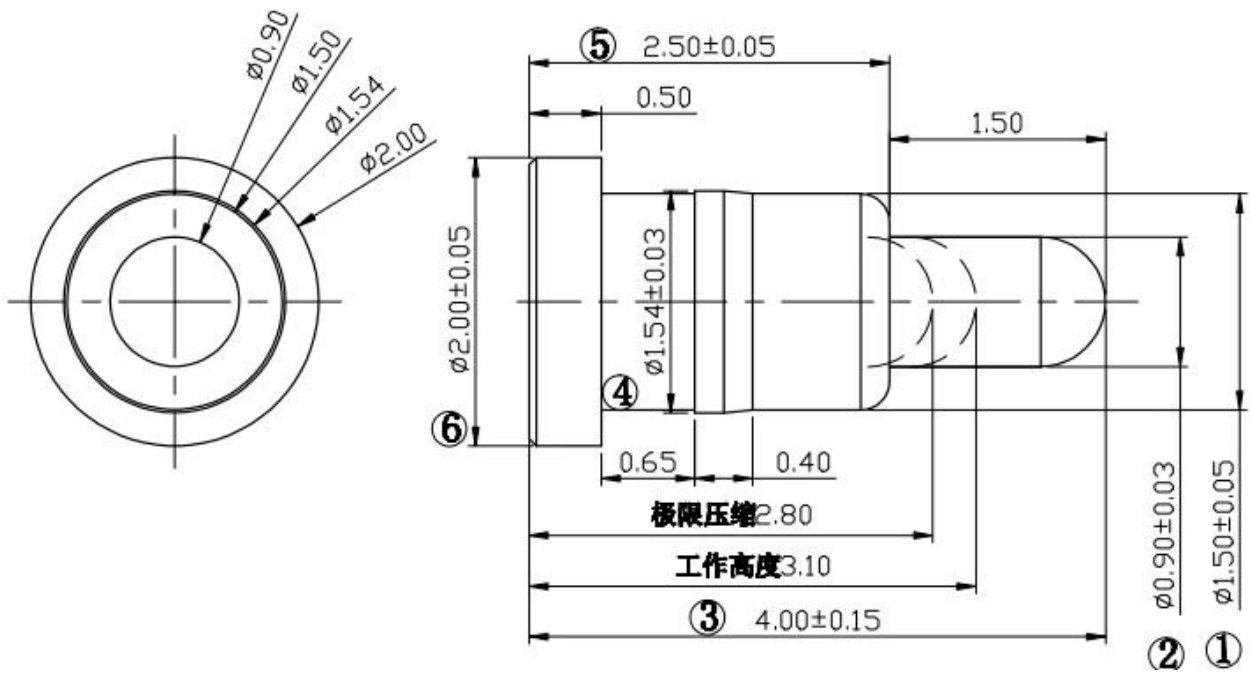

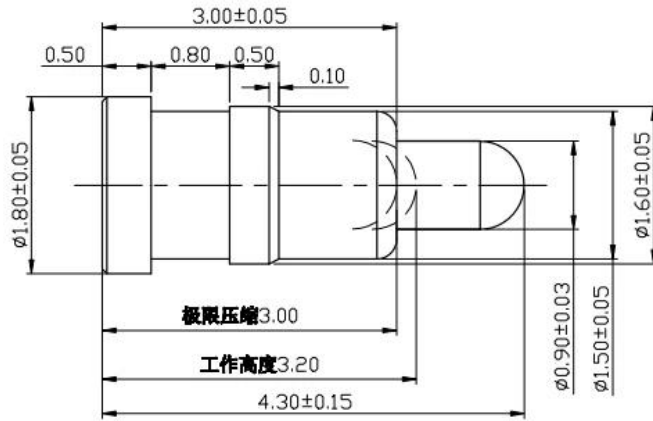

NOTE

1. Material  
Plunger: Brass 3604  
Barrel: Brass 3604  
Spring: SUS304  
Housing:
2. Plating  
Plunger: Au 10u" over 50~120u" Ni  
Barrel: Au 10u" over 50~120u" Ni  
Spring:
3. Electrical  
Rated current & voltage: DC 12V; 1.0A Max.



1. 24
2. OEM
- 3.
- 4.



1. PCB ICT FCT;
2. 2
3. BGA
4. QZ VZ LM;
- 5.;
6. /
7. 30# OK POM





1. Raw material warehouse



2. Lathe workshop



3. Assemble workshop



4. Quality inspection



5. Finished products



6. Packing



1. Agilent current testing



2. Quadratic element



3. Load Curve Meter



4. Bond Test



5. Life Fatigue Test



6. Microscope







