

□□ □□

□□ □□	SF5880
□□ □□□	3A
□□ □□	50mΩ □□
□□ □□	4.0mm
□□□ □	200±20%gf@ □□ 4.0mm
MOQ	100PCS
□□ □□	100% T/T □□ □
□□ □□	□□□□ □□ □ 5~10□

□□ □□

SF-P160

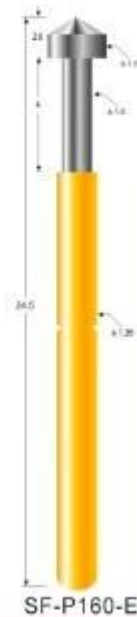
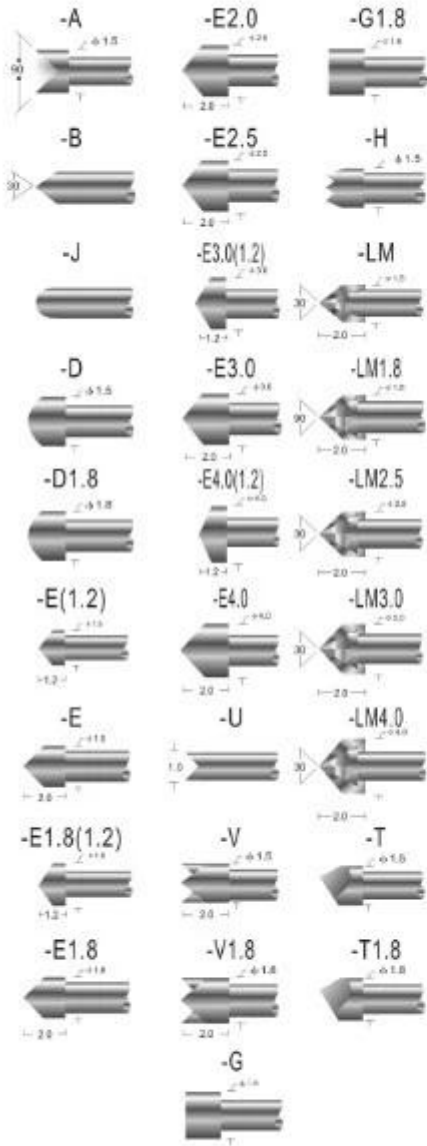

Probe specifications SF-P160(技术规格)

- Recommended minimum center(最小间距): 2.54mm(.1000 ")
- Mounting hole size(钻孔尺寸):
压克力: 1.70mm(.0670 ")
电木板、玻璃纤维板: 1.75mm(.0689 ")
- Full travel(行程): 4.0(.1575 ")
- Spring force(弹簧压力): 200g
- Materials and finishes(材料及涂饰):
Plunger: Be Cu, Rh plated; SK4, Rh plated
Barrel: Brass, Gold plated
Spring: Stainless steel
- Current ration(额定电流): 3A(安培)
- Contact resistance(接触电阻): 50mΩ (毫欧姆)

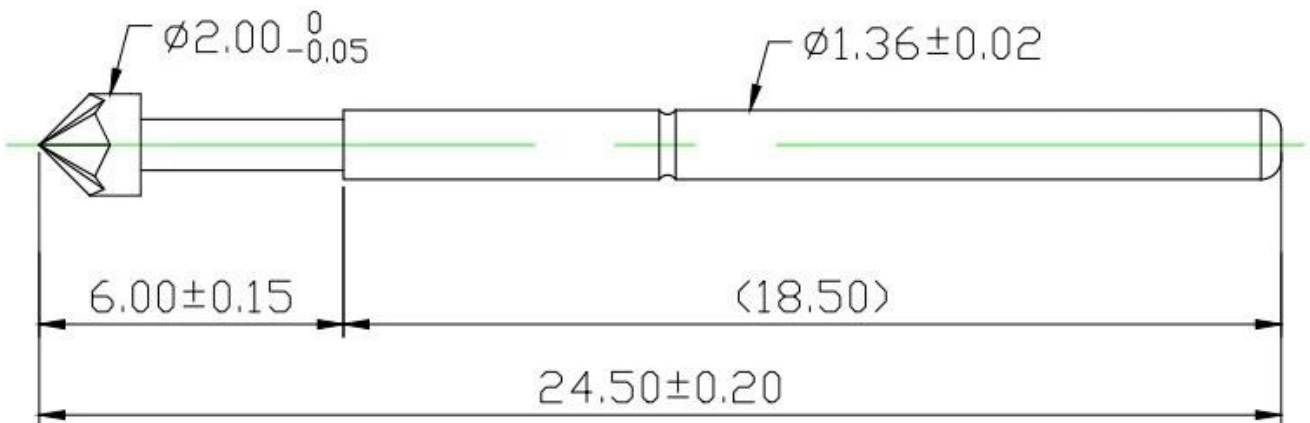



Production Flow (生产流程)



1. raw material warehouse



2. Lathe workshop



3. Assemble workshop



4. Quality inspection



5. Finished products



6. Packing



Measuring Equipment >

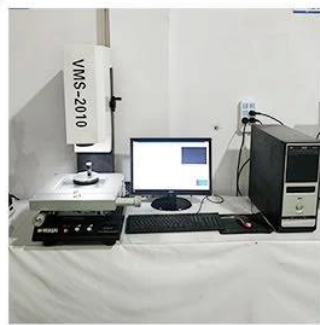

Measuring Equipment:

1. Agilent current testing;
2. Quadratic element measurement
3. Load Curve Meter
4. Bond Test
5. Life Fatigue Test





□□ □□



Quality Management System Certificate of Approval

This is to certify that the QMS of

Suzhou Shengyifurui Electronic Technology Co.,Ltd

Unified Social Credit Code:91320506MA1NRNLF6N

Registration Address:Room 5277 Tianlong Building, No.378 Zhujiang Nan Road, Mudu Town,
Wuzhong District, Suzhou City

Business Address:Room 103 Units 2 Building 4, Xiangtihuayuan, No.567 Binhe Road, SND, Suzhou City

Has been assessed and found to meet the requirements of

GB/T 19001-2016/ISO 9001:2015

This certificate is valid for the following scope of operations:

Sales of test probes and related accessories

Date of Certificate Issue: Dec, 06, 2018

Certificate Valid Until: Dec, 05, 2021

Certificate Number: **QM291812020**

The validity of the registration will be continued only when the organisation pass the annual surveillance audit.

Check the validity of certificate at www.cnca.gov.cn or www.das-china.com

Surveillance Audits:

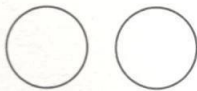

Authorized by:

Chief Executive



Shanghai DAS Certification Co., Ltd. , member of SN Registrars(Holdings) Ltd.

Add:505, Tower. 2, Guoson Center, No. 388, Zhongjiang Road, Shanghai, P.R.China, 200062

Tel: 0086-21-62773910 Fax:0086-21-62080319

Web:<http://www.das-china.com>

Email: info@das-china.com

UK Head Office:DAS Certification Limited (On Behalf of SN Registrars (Holdings) Limited)

ADD: Registration House, 22b Church Street, Rushden,

Northamptonshire, NN10 9YT, UK

Tel:+44(0)1933 381859

Email: info@dascertification.co.uk

Web: www.dascertification.co.uk

Company Number: 07659067



1. PCB, ICT, FCT □□□ □□ □□ □□ □□ □□□□;

- 2. 200, 200 200, 2000, 2000 0 200000 20000000 200 0 200 2000 200 200 2000 2000 2000 200 2(2000);
- 3. BGA 0 2000 20000 200 200 200 2000;
- 4. 20000 200 200 0, 200 0, QZ 0 VZ 20000 200 LM 0;
- 5. 2000 2000, 2000 2000, 200000 200;
- 6. 2000 0 2000/200;
- 7. 200 200 200 200, 200 200 200, POM 0 0.

2000 20000 200 200 20000 2000 20000. 2000 2000 200 2000 2000 200 2000 2000000 200 2000 200 2000 20000.

2000 2000

- 1. 2000 2000 2000 20000 2400 2000 2000 200 0 20000.
- 2. 2000 20000 20000 OEM 0 200000.
- 3. 2000 0 200 20000 2000 20000 2000 200 2000 0 20000.
- 4. 2000 20000 20000 2000 200 20000 2000 0 20000.